

Pegler Valve

Chromium plated brass full bore ball valve (red "T" handle) PN16. Compression ends to EN 1254/2.CE

PB300T Ball valve



General Information

Size	Pattern No.	Pack 1 Qty	Pack 2 Qty	Code	Barcode	Price (£) each ex VAT
15mm PB300T		10	80	255001	5013866029950	£21.49
22mm PB300T		10	40	255002	5013866029967	£28.47
28mm PB300T		5	20	255003	5013866029974	£40.28

PB300T Ball valve

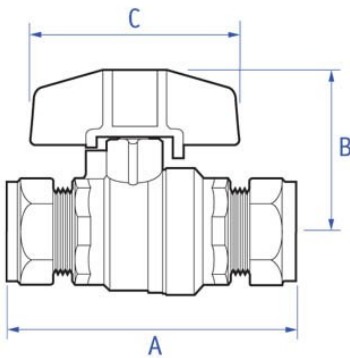

Dimensions

Code	Description	A	B	C
255001	15MM PB300T BRASS BALL VALVE CXC 77	42	50	0.220
255002	22MM PB300T BRASS BALL VALVE CXC 85	54	60	0.386
255003	28MM PB300T BRASS BALL VALVE CXC 100	57	60	0.561

Pegler Yorkshire reserve the right to change specifications

Flow Rate

Size	Pattern No.	Code	Kv m3/h
15mm PB300T		255001	17.00
22mm PB300T		255002	41.00
28mm PB300T		255003	70.00

Pegler Yorkshire reserve the right to change specifications

Pressure and Temperature

Description	Minimum Operating Pressure (bar)	Maximum Cold Working Pressure (bar)	Maximum Hot Working Pressure (bar)
PB300T Ball valve	No Minimum Operating Pressure	16.0 bar at temperatures up to 30oC	5.0 bar at temperatures up to 120oC

Care and Maintenance

Care

No regular aesthetic care is required for this product

Maintenance

A regular maintenance program is the most efficient method of ensuring longer term operational efficiency of the selected valve. Such a program would need to include a risk assessment and a planned procedure of how the maintenance will be carried out. The possibility of operational limits being exceeded and the

potential hazards ensuring must be considered as part of this assessment. This should be implemented to include visual checks on the valve's condition and any development of unforeseen conditions, which could lead to failure. The correct fitting tools and equipment should be used for valve maintenance work. Separate means of draining the pipe work must be provided when carrying out any maintenance to valves. Where there may be any system debris this could be collected and /or filtered by installation of the appropriate protective device.

For further help please contact your local engineer.

If your product is under warranty please contact the Service Support Team on: 0800 1560050

Regulations

Regulations

THE PRESSURE EQUIPMENT DIRECTIVE 97/23/EC and CE MARKING

The Pressure Equipment Regulations 1999 (SI 1999/2001) have now been introduced into United Kingdom law.

Valves with a maximum allowable pressure greater than 0.5 bar are covered by these new Regulations. Valves are categorised according to their maximum working pressure, size and rising level of hazard. The level of hazard varies according to the fluid being carried. Fluids are classified as Group 1, dangerous fluids or Group 2, all other fluids including steam. The Categories designated are SEP (sound engineering practice). Valves up to and including 25mm (1") are designated SEP regardless of the fluid group. Those identified as having increased hazard are Categorised as, I, II, III or IV. All valves designated as SEP do not bear the CE mark nor require a Declaration of Conformity. Categories I, II, III or IV carry the CE mark and require a Declaration of Conformity. Valves classified from the piping chart would not be included in Category IV.

Size Pattern No. Code PED Categorisation

15mm PB300T	255001 SEP
22mm PB300T	255002 SEP
28mm PB300T	255003 SEP

Pegler Yorkshire reserve the right to change specifications

Materials

Component	Material
Body	Forged Brass, Chrome Plated
End Piece	Forged Brass, Chrome Plated
Ball	Brass Bar, Chrome Plated (15mm) Forged Brass, Chrome Plated (22 to 28mm)
Stem	Brass Bar
Seats	PTFE (Teflon)
Thrust Washer	PTFE (Teflon)
Stem O Ring	Viton
Compression Nut	Forged Brass, Chrome Plated
Compression Cone	Brass
Red Tee Handle	Aluminium, Painted
Security Screws	Nickel Plated Brass

Technical Suitability

Steam	Water	Oil	Air	Gas	Inert Gas	Combustible†	Gas Corrosive††	Gas Oxygen
yes	yes	yes	yes	no	no	no	no	no

Pegler Yorkshire reserve the right to change specifications

Gas application guide

Class 1. INERT Air, argon, carbon dioxide, helium, nitrogen

Class 2. COMBUSTIBLE Hydrogen, methane, natural gas, town gas

Class 3. CORROSIVE Chlorine, sulphur dioxide Class 4. OXYGEN

Class 1. INERT Air, argon, carbon dioxide, helium, nitrogen

† Valves are suitable for British Gas Applications Family Gases 1, 2 and 3.

†† Suitable in applications where moisture is completely absent.

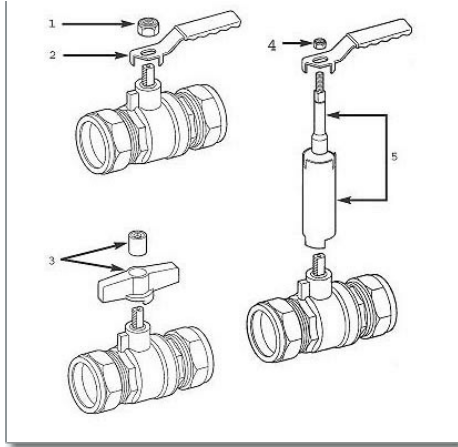

Spare Key	Description	Code	Barcode	Date From	Date To	Price (£) ex VAT
3						
3	HDT3 T HANDLE (RED)	850574	5013866061394	01/01/1900	08/03/2022	£0.00
3	HDT4 T HANDLE (RED)	850575	5013866061400	01/01/1900	08/03/2022	£0.00
3	HDT4 T HANDLE (RED)	850575	5013866061400	01/01/1900	08/03/2022	£0.00

Pegler Yorkshire Group Ltd, St Catherine's Ave, Doncaster, S Yorkshire, DN4 8DF
 Telephone: Phone +44 (0) 844 243 4400 Fax: +44 (0) 844 243 9870 Website: www.pegleryorkshire.co.uk
 Registered office : Pegler Yorkshire Group Ltd, St Catherine's Ave, Doncaster, S Yorkshire, DN4 8DF Company no : 00401507